

Steel	
Material Standard:	BS 1449 Part2:1983
Specification:	BS 6946:1988
Finishing:	hot dip galvanized to ISO 1461:1999

CA01

Item No.

40011

No.	A mm	Recommended UDL Kgf for vertical channel DR41	Wt. each kg
CA01/150	160	680	0.80
CA01/300	310	356	1.17
CA01/450	460	240	1.59
CA01/600	610	181	2.03
CA01/750	760	143	2.53

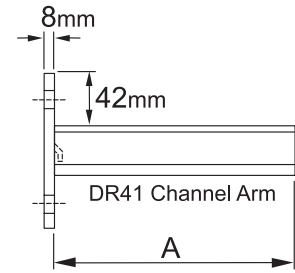
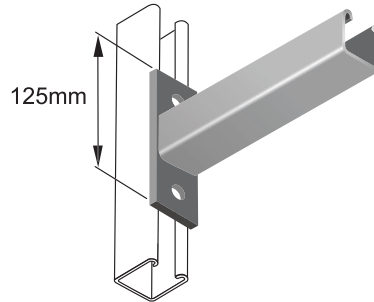

Available in slotware type

CA02

Item No.

40012

No.	A mm	Recommended UDL Kgf for vertical channel DR41	Wt. each kg
CA02/150	160	680	0.80
CA02/300	310	356	1.17
CA02/450	460	240	1.59
CA02/600	610	181	2.03
CA02/750	760	143	2.53

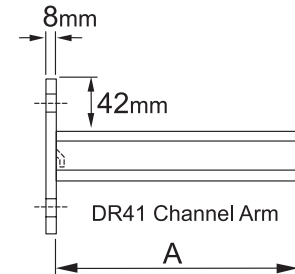
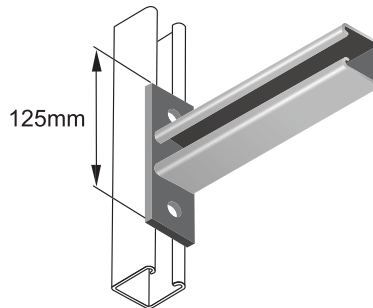

Available in slotware type

CA03

Item No.

40013

No.	A mm	Recommended UDL Kgf for vertical channel DR41D	Wt. each kg
CA03/300	310	609	2.13
CA03/450	460	410	3.01
CA03/600	610	309	3.72
CA03/750	760	248	4.66

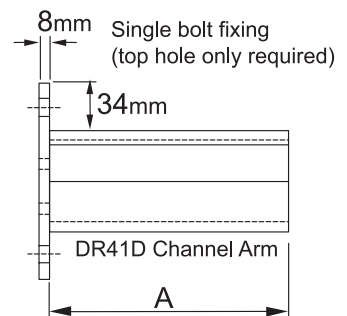
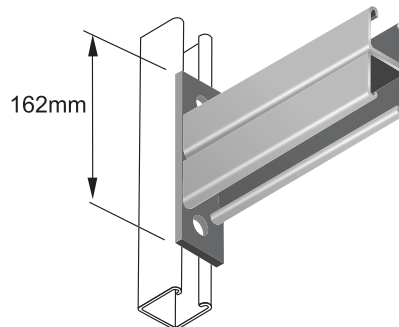

CA04

Item No.

40014

No.	A mm	B mm	C mm	Recommended UDL Kgf for vertical channel DR41	Wt. each kg
CA04/750	760	270	608	460	4.63
CA04/900	910	330	728	460	4.78
CA04/1050	1060	380	848	460	5.67

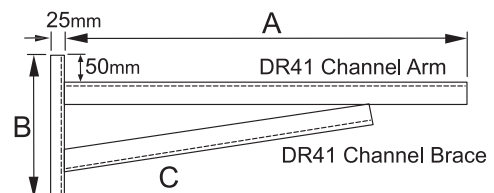
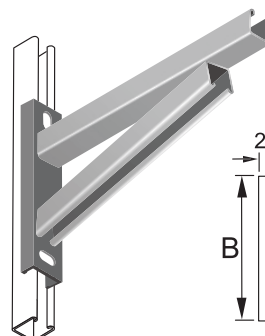

Grade 304 & 316 Stainless Steel and special length available on request
 Ordering example : Hot dip galvanized CA01/150 Channel Arms (item no : 4001101150)