

JAM-S Steel Zinc Plated Sleeve Anchor

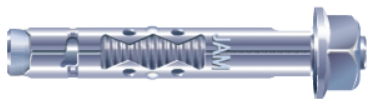
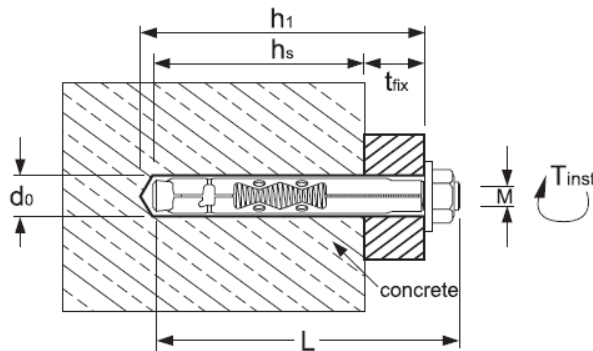

Application

- installing pipe bracket, trucking, cable tray and suspended ceilings. Light to medium metalwork, hand rails, signs and gates etc.

Material

- steel, zinc plated $\geq 5\mu\text{m}$;
A2/304 stainless steel

Base material

- concrete, brick, masonry and hollow brick
(Concrete fcc = 30N/mm²)

Item No.	Description	Hole Diameter d_o (mm)	Thread Size x L (mm)	Min. Hole Depth h_s (mm)	Tightening Torque T_{inst} (Nm)	Fixture Thickness t_{fix} (mm)	Base Material Thickness (mm)	Recommended Tensile Load (kN)	Recommended Shear Load (kN)
2010106040	S 8 x 40	8	M6 x 47	28	8	12	80	1.9	3.0
2010108050	S 10 x 50	10	M8 x 60	32	25	18	100	3.8	4.4
2010110060	S 12 x 60	12	M10 x 69	38	40	22	120	5.5	7.2
2010110075	S 12 x 75	12	M10 x 84	38	40	37	150	5.5	7.2

JAM-S A2 Stainless Steel Sleeve Anchor



Item No.	Description	Hole Diameter d_o (mm)	Thread Size x L (mm)	Min. Hole Depth h_s (mm)	Tightening Torque T_{inst} (Nm)	Fixture Thickness t_{fix} (mm)	Base Material Thickness (mm)	Recommended Tensile Load (kN)	Recommended Shear Load (kN)
2010606040	S 8 x 40 A2	8	M6 x 47	28	8	12	80	1.9	3.0
2010608050	S 10 x 50 A2	10	M8 x 60	32	25	18	100	3.8	4.4
2010610060	S 12 x 60 A2	12	M10 x 69	38	40	22	120	5.5	7.2

JAM-SH Steel Zinc Plated Sleeve Anchor



Item No.	Description	Hole Diameter d_o (mm)	Thread Size x L (mm)	Min. Hole Depth h_s (mm)	Tightening Torque T_{inst} (Nm)	Fixture Thickness t_{fix} (mm)	Base Material Thickness (mm)	Recommended Tensile Load (kN)	Recommended Shear Load (kN)
2010206045	SH 8 x 45	8	M6 x 49	38	10	7	100	2.8	3.5
2010206060	SH 8 x 60	8	M6 x 64	38	10	22	100	2.8	3.5
2010208060	SH 10 x 60	10	M8 x 66	44	25	16	120	4.0	4.8
2010208085	SH 10 x 85	10	M8 x 91	44	25	41	120	4.0	4.8
2010208110	SH 10 x 110	10	M8 x 110	44	25	66	120	4.0	4.8
2010210065	SH 12 x 65	12	M10 x 71	56	40	9	120	5.9	7.8
2010210080	SH 12 x 80	12	M10 x 86	56	40	24	150	5.9	7.8
2010210110	SH 12 x 110	12	M10 x 116	56	40	54	200	5.9	7.8
2010212110	SH 16 x 110	16	M12 x 116	55	70	55	200	8.3	9.5

Installation of JAM-S, JAM-SH Sleeve Anchor

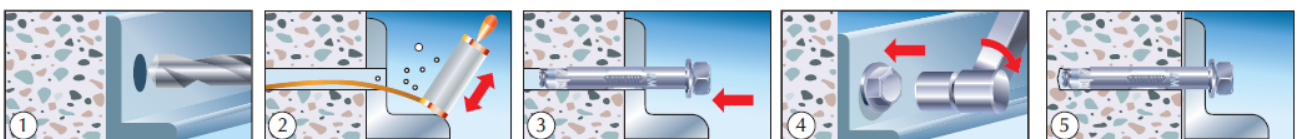

1. Drill to specified diameter and depth.
2. Clean the hole with blow-out bulb.
3. Push anchor carefully with hand into hole until nut and washer are flush with fixture.
4. Tighten with the wrench to the recommended torque value.